



# Combustion measurement of thermoacoustic oscillating flames by diode-laser absorption spectroscopy sensors<sup>☆</sup>

M. Shimura<sup>a</sup>, M. Tanahashi<sup>a</sup>, T. Miyauchi<sup>a</sup>, G.-M. Choi<sup>b,\*</sup>, D.-J. Kim<sup>b</sup>

<sup>a</sup> Department of Mechanical and Aerospace Engineering, Tokyo Institute of Technology, 2-12-1 Ookayama, Meguro-ku, Tokyo 152-8552, Japan

<sup>b</sup> Pusan Clean Coal Center, Pusan National University, 30 Jangjeon-dong, Geumjeoung-ku, Busan 609-735, Republic of Korea

## ARTICLE INFO

### Article history:

Received 29 July 2008

Received in revised form 3 June 2009

Accepted 8 June 2009

Available online 17 June 2009

### Keywords:

Thermoacoustic oscillating flame  
Diode-laser absorption spectroscopy  
High frequency detection  
Combustion control

## ABSTRACT

Diode-laser absorption spectroscopy has been applied to a swirl-stabilized turbulent combustor to detect high frequency combustion oscillation and combustion state related to combustion noise. Two diode-laser absorption spectroscopy techniques of scanned-wavelength method and fixed-wavelength method are adopted. In the scanned-wavelength method, fluctuations of temperature and H<sub>2</sub>O mole fraction up to 1 kHz are detected. Two dominant peak frequencies of power spectra of these fluctuations, which are about 125 Hz and 140 Hz, coincide with those of pressure fluctuation in the combustor. In the case of control by secondary fuel injection, the energy at peak frequency of temperature and H<sub>2</sub>O mole fraction decreases in accordance with noise reduction. Similar to the combustion noise, temperature fluctuation shows a minimal value at the appropriate frequency of secondary fuel injection. By analysing transmitted signals, the fixed-wavelength method provides power spectra similar to those obtained by the scanned-wavelength method. The advantage of the fixed-wavelength method is capability of detection of high frequency combustion oscillation more than 1 kHz. These results prove that the diode-laser absorption spectroscopy has great applicability as sensors for the combustion measurement of thermoacoustic oscillating flames and active control of turbulent combustion.

© 2009 Elsevier B.V. All rights reserved.

## 1. Introduction

Lean premixed combustion is considered to be a candidate for low NO<sub>x</sub> emission and high efficiency gas turbines. However, the lean premixed combustion may induce combustion oscillation, which generates combustion noise and damages combustor system mechanically. Therefore, the reductions of the combustion oscillation and the combustion noise are required to realize high efficiency and low emission combustor.

There are two approaches to suppress the combustion oscillation. One is passive combustion control, which is optimally designed for individual combustor system to prevent combustion oscillation. The other is active combustion control, which is based on feedback control by combustion monitoring. At present, the standard technique to suppress the combustion oscillations is the passive combustion control. It is recognized that the passive combustion control restricts the operating condition of the combustor. On the other hand, the active combustion control might be applied to the combustors for a wide range of the operating conditions, and

tune the operating condition optimally so as to suppress combustion oscillation. Active combustion control has advantages in terms of generality and optimization. To realize active combustion control, high temporal and sensitive sensors for combustion monitoring are required.

It is considered that most of combustion oscillations and instabilities are caused by feedback interaction between the natural acoustic mode of combustor and fluctuation of heat release rate [1]. To detect combustion oscillations, sensing of pressure, temperature and combustion products is necessary, whereas those quantities include high temporal fluctuation in general. Therefore, in the active combustion control, sensors with high temporal resolution and high accuracy are required to monitor combustion oscillation and to give appropriate control signals for actuators.

Non-intrusive temperature and concentration sensors using lasers are attractive in many situations where measurements must be made in a hot and/or erosive environment such as industrial furnace and gas turbine combustor, etc. Diode-laser absorption techniques have been developed for real-time combustion monitoring. In the diode-laser absorption spectroscopy, absorption lines by molecule which can reflect combustion state are used to measure temperature, mole fraction and velocity. In the previous studies, diode-laser absorption techniques for H<sub>2</sub>O [2,3], CO [4–7], CO<sub>2</sub> [8,9] and NO<sub>2</sub> [10] have been developed. In order to increase the sensitivity of absorption coefficient measurement, wavelength modulation

<sup>☆</sup> This paper was presented at 8th Symposium of the Korean Society of Thermo-physical Properties held at POSTECH, Korea from April 24–25, 2008.

\* Corresponding author. Tel.: +82 51 5102476; fax: +82 51 5125236.

E-mail address: [choigm@pusan.ac.kr](mailto:choigm@pusan.ac.kr) (G.-M. Choi).

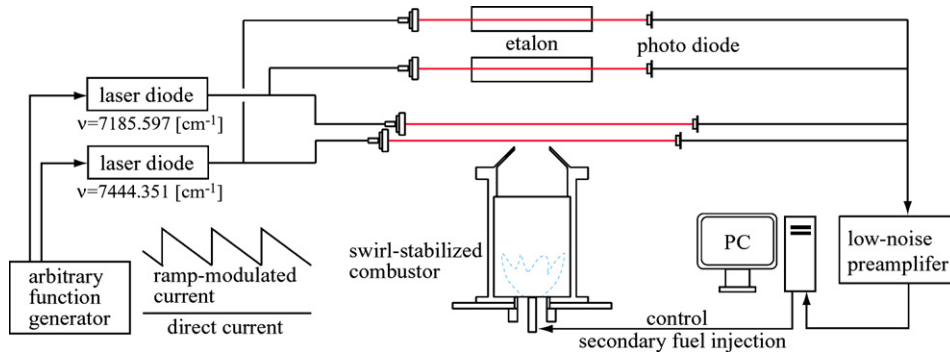

Fig. 1. Experimental set-up of diode-laser absorption spectroscopy system.

spectroscopy (WMS) was selected [11,12]. This WMS method has been used for measuring low concentration species such as NO [13] and CO [6], and combusting gases on the micro-gravity field were also measured [14]. Since the sensor system based on diode-laser absorption, which is small and simple, has high temporal resolution, high sensitivity and non-intrusive characteristics, it has great possibility to be used for combustion monitoring in many engineering applications. For combustion controls, the diode-laser absorption has been used as sensors in the Hencken burner [15], 50 kW incinerator [16], 5 kW dump combustor [17], pulse detonation engine [18,19] and swirl-stabilized combustor [20]. Although the gas composition and temperature were not uniform along the sensor line of sight, combustion oscillations and fluctuations were clearly obtained. However, researches on applicability of these techniques for turbulent combustion fields are scarcely found in spite of the fact that turbulent combustion has been adopted in many engineering applications. In addition, a detail understanding about relationship between pressure fluctuations and sensing properties by diode-laser is necessary to adopt this diode-laser absorption sensor to active control of turbulent flames efficiently.

In this study, in-situ combustion measurements in a swirl-stabilized turbulent combustor by diode-laser absorption spectroscopy sensors are conducted to investigate the suitability of the diode-laser absorption for detection of high frequency combustion oscillation and understand the detail characteristics of oscillating flames.

## 2. Absorption spectroscopy

Absorption spectroscopy is based on the Lambert–Beer law as follows [2]:

$$\left(\frac{I}{I_0}\right)_\nu = \exp(-\kappa(\nu)L) \quad (1)$$

where  $I_0$  is the intensity of incident radiation,  $I$  is the intensity of transmitted radiation,  $\kappa(\nu)$  is absorption coefficient,  $L$  is the length of homogeneous absorbing media in which laser passes and  $\kappa(\nu)L$  is defined as absorbance. The absorption coefficient is expressed as:

$$\kappa(\nu) = P X_{\text{abs}} \sum_{i=1}^N S_i(T) \phi(\nu - \nu_{0,i}) \quad (2)$$

where  $P$  is total pressure,  $X_{\text{abs}}$  is mole fraction of absorbing species,  $i$  is an index that denotes a particular transition,  $N$  is the number of probed transition,  $S_i(T)$  is the line strength of transition  $i$  centred at  $\nu_{0,i}$  and  $\phi(\nu - \nu_{0,i})$  is the line shape function which is normalized by the following equation:

$$\int \phi(\nu - \nu_{0,i}) d\nu \equiv 1 \quad (3)$$

The line strength is expressed by using the line strength at reference temperature,  $T_0$ , as follows:

$$S_i(T) = \frac{S_i(T_0)(T_0/T)(Q(T_0)/Q(T))(1 - \exp(-hc\nu_{0,i}/kT))}{(1 - \exp(-hc\nu_{0,i}/kT_0)) \exp(-hc/kE''(1/T - 1/T_0))} \quad (4)$$

where  $Q(T)$  is the molecular partition function and  $E''$  is the lower-state energy. The line strength at reference temperature and the lower-state energy are taken from HITRAN2004 database [21].

The frequency integral of the absorbance is independent of the line shape function and is expressed as follows:

$$\int \kappa(\nu)L d\nu = P X_{\text{abs}} L \sum_{i=1}^N S_i(T) \quad (5)$$

The temperature can be obtained from the ratio of two integrated absorbance in the different transitions (denoted by 1 and 2 below) at the same total pressure, mole fraction of absorbing species and length of the homogeneous media. The ratio is expressed as a function of temperature as follows:

$$R = \frac{\int \kappa_1(\nu) d\nu}{\int \kappa_2(\nu) d\nu} = \frac{\left(\sum_{i=1}^{N_1} S_i(T_0) \exp(-hcE''_i/k(1/T - 1/T_0))\right)}{\left(\sum_{j=1}^{N_2} S_j(T_0) \exp(-hcE''_j/k(1/T - 1/T_0))\right)} \quad (6)$$

Mole fraction of the absorbing species at the measured temperature is expressed as:

$$X_{\text{abs}} = \frac{\left(\int \kappa(\nu) d\nu\right)}{\left(P \sum_{i=1}^N S_i(T)\right)} \quad (7)$$

The ratio of the peak values of two absorbance depends on not only temperature but also line shape function, which is as follows:

$$R_{\text{peak}} = \frac{\left(\kappa_1(\nu_{p_1})\right)}{\left(\kappa_2(\nu_{p_2})\right)} = \frac{\left(\sum_{i=1}^{N_1} S_i(T_0) \phi(\nu_{p_1} - \nu_{0,i}) \exp(-hcE''_i/k(1/T - 1/T_0))\right)}{\left(\sum_{j=1}^{N_2} S_j(T_0) \phi(\nu_{p_2} - \nu_{0,j}) \exp(-hcE''_j/k(1/T - 1/T_0))\right)} \quad (8)$$

## 3. Experimental method

### 3.1. Experimental set-up

Fig. 1 shows experimental set-up of the diode-laser absorption spectroscopy. Scanned-wavelength method and fixed-wavelength method are used in the present study. In the scanned-wavelength method, two diode-lasers (NTT Electronics, NT-L200-STD, 15 mW) were tuned across  $\text{H}_2\text{O}$  transitions near 1343 nm ( $\nu_1 + \nu_3$  band)

and 1392 nm ( $2\nu_1$  and  $\nu_1 + \nu_3$  bands) by ramp-modulated current from arbitrary function generator. Since  $\text{H}_2\text{O}$  is one of the main products of hydrogen and hydrocarbon combustions and indicates state of the burnt gas, it is desirable to use  $\text{H}_2\text{O}$  as absorbing gas to monitor combustion condition. In  $\text{H}_2\text{O}$  transitions, wavelength regions near 1343 nm and 1392 nm are widely used [3], because line strengths of transitions in these wavelengths are relatively high and independent of absorption spectra of other species. Radiations of two diode-lasers were lead to measuring area by fiber optics (Newport), and were passed through 5 mm downstream of the exit of swirl-stabilized turbulent combustor. Transmitted radiations were detected by photo diodes (Hamamatsu photonics, B1918-01) and detected signals were recorded by PC with 12bit A/D converter. Etalons (Laser Mate Inc., BK7 Solid Etalon) with 2 GHz free spectral range were used for the conversion of transmitted signals from a time-dependent form to a wavelength-dependent one. Wavelengths of two diode-lasers were scanned over entire line shapes from 1343.1 nm to 1343.4 nm and from 1391.5 nm to 1391.8 nm. In this study, diode-lasers were tuned at 2 kHz repetition rate and the transmitted signals were recorded at 1 MHz. This set-up of diode-laser absorption spectroscopy can be used for the combustion oscillation with higher frequency by using a fixed-wavelength method. In the fixed-wavelength method, wavelengths of diode-lasers were fixed near the peak absorption. The transmitted signals were recorded at 10 kHz. Therefore, fixed-wavelength method can detect fluctuation up to 5 kHz.

In this study, a swirl-stabilized turbulent combustor, which has been investigated by our previous works [22,23], is used. The combustor can be controlled by secondary fuel injection. Fig. 2 shows the schematics of swirl-stabilized turbulent combustor and details of secondary fuel injection nozzle. This combustor rig consists of a contraction section, a swirl nozzle section and combustion chamber. The swirl nozzle of 40 mm inner diameter is mounted on the contraction section. The inner cross-section of combustion chamber is  $120 \times 120 \text{ mm}^2$ , and the length of the chamber is 590 mm. The swirl nozzle has swirl vanes of 14 mm inner diameter and 40 mm outer diameter, inclined  $45^\circ$  from the nozzle axis. The secondary fuel nozzle is mounted at the centre of the swirl vanes and has eight injection holes (ID=0.6 mm) inclined  $45^\circ$  from the mainstream direction. The premixed methane–air mixture passes through the swirl vanes and the flame is stabilized on the swirl vanes.

### 3.2. Characteristics of swirl-stabilized combustor

The characteristics of the present combustor have been reported for no injection and continuous secondary fuel injection cases by Choi et al. [23] and for intermittent secondary fuel injection cases by Tanahashi et al. [22]. Here, important characteristics are summarized briefly. It has been reported that secondary pure fuel injection suppresses pressure fluctuation in the combustion chamber and reduces combustion noise without the increase of emission index of  $\text{NO}_x$ . The largest noise reduction was observed for the condition of the secondary pure fuel flow rate ( $V_{sf}$ ), which is 1% of flow rate of the main stream ( $V_m$ ). Dilutions of the secondary fuel by air lead to lower effects for the noise reduction. By inject-

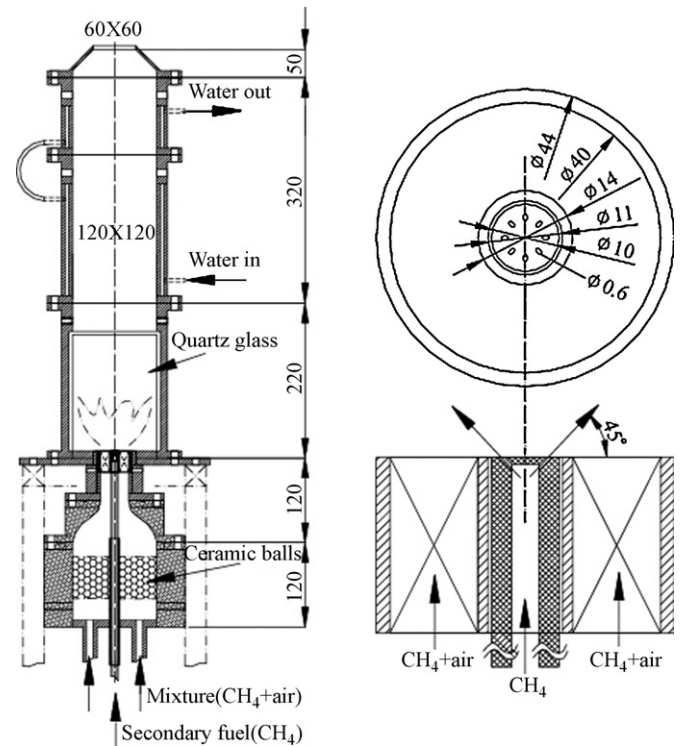

Fig. 2. Schematics of swirl-stabilized turbulent combustor and details of secondary fuel injection nozzle.

ing secondary fuel continuously, noise is decreased about 15 dB compared with the case without secondary fuel injection. If the secondary fuel is injected intermittently with appropriate frequency of 40 Hz, the combustion noise is further reduced about 5 dB. Note that the noise level increases again if the secondary fuel injection frequency exceeds 40 Hz. The peak frequency of the pressure fluctuation in the combustor and noise is about 130 Hz for the no injection case, which is related to natural resonance frequency of the combustor depending on the mean temperature of combustion chamber. The appropriate frequency of the secondary fuel injection for noise reduction is lower than those peak frequencies and seems to coincide with the beating frequency observed in the pressure fluctuation [23].

### 3.3. Experimental conditions

In this study, the flow rate of the main methane–air mixture is selected to  $V_m = 300 \text{ l/min}$  for all cases. As for the cases with the secondary fuel injection, pure methane is used for the secondary fuel and  $V_{sf}$  is set to be 1% of  $V_m$ . As for a reference case, no injection case with equivalence ratio  $\phi = 0.717$  is selected. For the secondary fuel injection cases, the injection frequencies are continuous, 10 Hz, 40 Hz and 70 Hz. The combustion noise level is 100 dB for continuous case, 98 dB for 10 Hz, 95 dB for 40 Hz and 104 dB for 70 Hz. The total equivalence ratio is 0.819 for these cases.

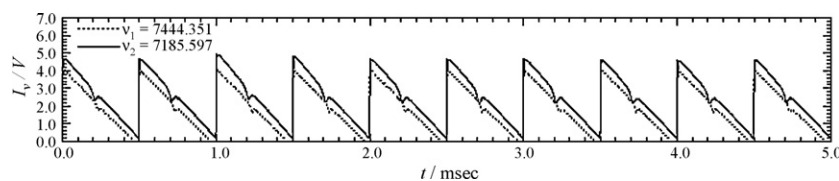

Fig. 3. Transmitted signals of two diode-lasers tuned by the ramp-modulated current with a 2 kHz repetition rate.

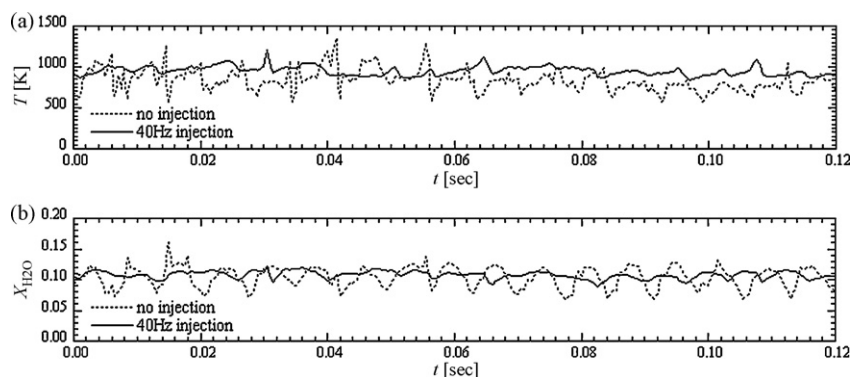

Fig. 4. Temperature (a) and H<sub>2</sub>O mole fraction (b) obtained by diode-laser absorption spectroscopy with 2 kHz at the exit of the swirl-stabilized turbulent combustor.

#### 4. Combustion measurements by scanned-wavelength method

Fig. 3 shows transmitted signals of two diode-lasers obtained for  $\phi = 0.717$  and  $V_m = 300$  l/min without secondary fuel injection. Individual time-dependent transmitted signal was transformed to a frequency-dependent line shape using information obtained from laser signal, which passed through the etalon. The frequency-dependent signals were normalized by the incident laser intensity as shown in Eq. (1). Measured absorbance includes not only the absorbance in burnt gas but also the absorbance in ambient air. In order to eliminate the absorbance by H<sub>2</sub>O in the ambient air, it is necessary to measure the absorbance of the circumstance, and to subtract the absorbance by the ambient air from the measured absorbance. Temperature of the burnt gas was determined from the ratio of a set of integrated absorbances by Eq. (6), and H<sub>2</sub>O mole fraction was determined from measured integrated absorbance and the calculated line strength at the measured temperature by using Eq. (7). Therefore, temperature and H<sub>2</sub>O mole fraction were measured at 2 kHz and fluctuation can be detected up to 1 kHz.

The estimated temperature and H<sub>2</sub>O mole fraction in the burnt gas for the cases of no secondary fuel injection and intermittent secondary fuel injection at 40 Hz are shown in Fig. 4. For the case of no secondary fuel injection, temperature and mole fraction show relatively large oscillations. The mean and r.m.s. value of measured temperature were 856 K and 151.5 K (17.7%) for without secondary fuel, 964 K and 60.7 K (6.3%) for intermittent secondary fuel at 40 Hz, respectively. On the other hand, the mean and r.m.s. value of measured H<sub>2</sub>O mole fraction was 0.0976 and 0.02 (20.6%) for without secondary fuel, 0.109 and 0.008 (7.3%) for intermittent secondary fuel at 40 Hz, respectively. Table 1 shows mean temperature and mole fraction measured by absorption method for all cases. In order to ensure the accuracy of the diode-laser absorption spectroscopy, temperature of the burnt gas was also measured by thermo-couple (ID = 100  $\mu$ m, Pt/Pt15%Rh) on the laser path every 3 mm from the edge to the centre of the exit of the combustion chamber. For the no injection case, the maximum time-averaged temperature measured by thermo-couple was 1120 K at the centre of the exit and the minimum one was 700 K at the edge of the exit. The temperature averaged in time and space by thermo-couple was 930 K for the no injection case. The difference of temperature between the absorption measurement and the thermo-couple is

Table 1  
Effects of secondary fuel injection on mean temperature and H<sub>2</sub>O mole fraction.

	No injection	Continuous	10 Hz	40 Hz	70 Hz
T (K)	856	929	993	964	957
X <sub>H<sub>2</sub>O</sub>	0.0976	0.107	0.115	0.109	0.111

about 80 K, which suggests that, even in the inhomogeneous field such as the exhaust of the swirl-stabilized turbulent combustor, diode-laser absorption spectroscopy can measure mean temperature sufficiently. For the case of the secondary fuel injection, mean temperature and mean H<sub>2</sub>O mole fraction escalates compared with no injection because total equivalence ratio increases by the secondary fuel injection. The H<sub>2</sub>O mole fraction from equilibrium calculation is about 0.14 for  $\phi = 0.717$  and 0.157 for  $\phi = 0.819$ . The measured H<sub>2</sub>O mole fraction values are relatively lower than equilibrium calculation results. These low concentrations ascribed to mixing between exhaust gases and surrounding air at the combustor exit. Sound level depends on the frequency of the secondary fuel injection and becomes minimum at 40 Hz, which is reported by Tanahashi et al. [22]. Compared with the no injection case, fluctuations of temperature and mole fraction are suppressed for the case of 40 Hz secondary fuel injection as shown in Fig. 4. The r.m.s. of temperature and mole fraction is shown in Table 2. For the cases of secondary fuel injection, fluctuations of temperature and H<sub>2</sub>O mole fraction are reduced significantly compared with the no injection case. Temperature fluctuation decreases in accordance with the decrease of the combustion noise. For 40 Hz secondary fuel injection, intensity of temperature fluctuation shows the minimal value, which is similar to the noise level. R.m.s. of temperature is 17.7% for no injection, 6.6% for continuous injection, 6.5% for 10 Hz, 6.3% for 40 Hz and 6.6% for 70 Hz. Therefore, the reduction of combustion noise can be detectable from r.m.s. of temperature fluctuation.

Power spectra of temperature and H<sub>2</sub>O mole fraction are shown in Fig. 5 for the no injection case and continuous secondary fuel injection case. In power spectra of temperature and H<sub>2</sub>O mole fraction for no injection case, two large peaks are observed at about 125 Hz and 140 Hz, which correspond to the peak frequencies of the pressure fluctuation in the swirl-stabilized turbulent combustor [22]. Since combustion oscillations are caused by feedback interaction between natural resonance of combustor and fluctuation of heat release rate, fluctuation of temperature, which is closely related to the fluctuation of heat release rate, shows the same frequency with that of pressure in the combustor. In addition, fluctuation of H<sub>2</sub>O mole fraction is associated with that of heat release rate, since H<sub>2</sub>O is one of combustion products. Therefore, diode-laser absorption spectroscopy can be used to detect the fluctuations of temperature and H<sub>2</sub>O mole fraction, which may correlate with the pressure fluctuation in the combustor. By injecting secondary

Table 2  
Effects of secondary fuel injection on r.m.s. values of temperature and H<sub>2</sub>O mole fraction.

	No injection	Continuous	10 Hz	40 Hz	70 Hz
T (%)	17.7	6.6	6.5	6.3	6.6
X <sub>H<sub>2</sub>O</sub> (%)	20.6	6.8	7.1	7.3	7.5

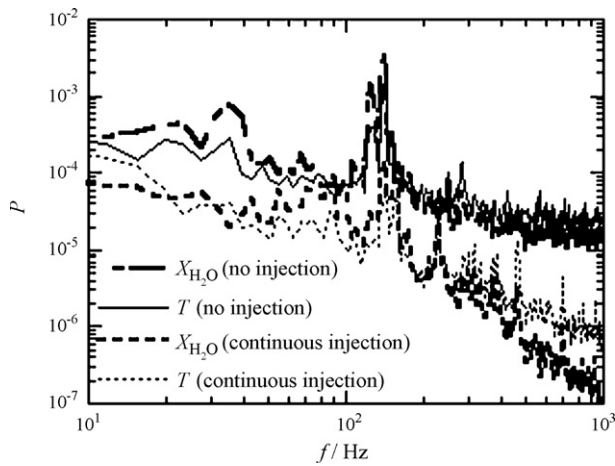

Fig. 5. Power spectra of temperature and H<sub>2</sub>O mole fraction obtained for no secondary fuel injection and continuous secondary fuel injection.

fuel continuously, energies at the peak frequencies are reduced and those of high frequencies decrease. However, a new peak is induced at about 230 Hz. These results indicate that continuous secondary fuel injection does not sufficiently suppress combustion oscillation and that new feedback interaction is induced by secondary fuel injection.

Fig. 6 shows effects of intermittent secondary fuel injection on fluctuations of temperature and H<sub>2</sub>O mole fraction. For the cases of intermittent secondary fuel injection, energies at the peak frequencies are suppressed compared with continuous secondary fuel injection case. However, new peaks are induced at injection fre-

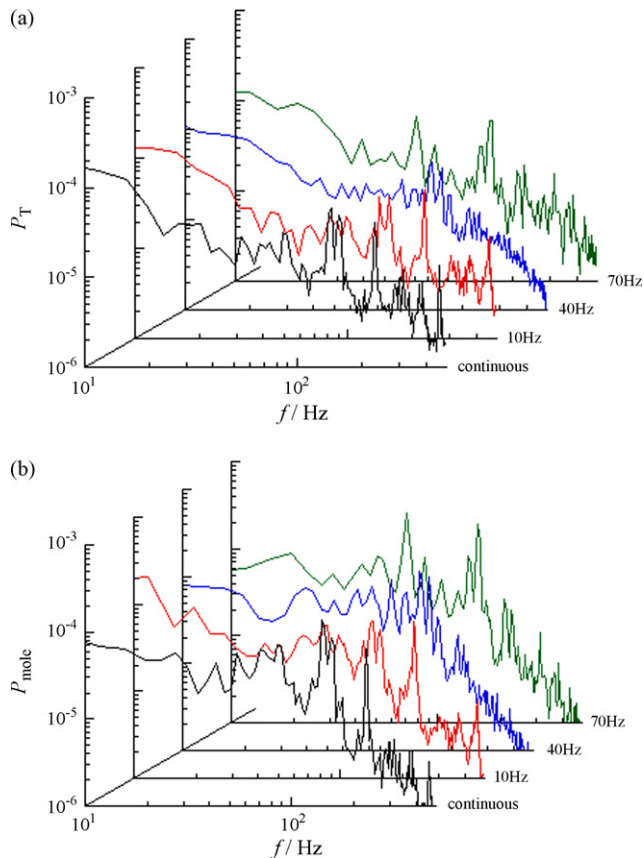

Fig. 6. Power spectra of temperature (a) and H<sub>2</sub>O mole fraction (b) obtained for continuous and intermittent secondary fuel injection.

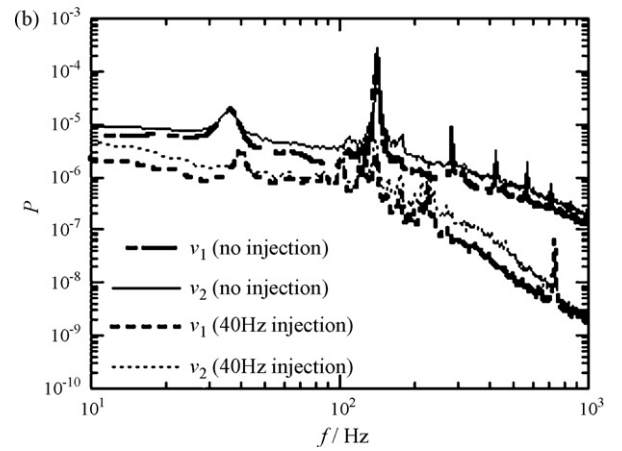
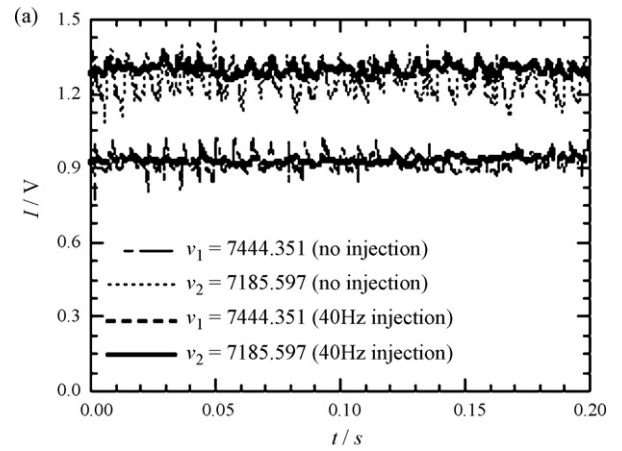

Fig. 7. Transmitted signals of two diode-lasers (a) and power spectra of transmitted signals for no secondary fuel injection case and 40 Hz injection case in fixed-wavelength method (b).

quencies. Especially for 70 Hz injection, the new peak energy is larger than peak energies of continuous injection case. This characteristic might be the reason why the noise level of 70 Hz injection is larger than that of continuous injection. On the other hand, for 40 Hz secondary fuel injection, which is appropriate for the reduction of combustion noise and the suppression of pressure fluctuation, the energy at injection frequency is relatively low and energies in high frequency region are low compared with the other injection cases. These results show that combustion oscillation and combustion state related to combustion noise can be detected by the power spectra of temperature and H<sub>2</sub>O mole fraction measured by using diode-laser absorption spectroscopy.

## 5. Combustion measurements by fixed-wavelength method

Transmitted signals of two diode-lasers fixed at the centre wavelengths of transitions are shown in Fig. 7(a) for the no fuel injection case and 40 Hz injection case. Transmitted signals show fluctuations similar to those of temperature and H<sub>2</sub>O mole fraction obtained by the scanned-wavelength method shown in Fig. 4. By injecting secondary fuel at 40 Hz, fluctuation of the signals is suppressed about 3%. Power spectra of these signals are shown in Fig. 7(b). Power spectra obtained by fixed-wavelength method shows similar tendency of those by scanned-wavelength method. The energy at the peak frequency and in high frequency region is reduced for 40 Hz injection case remarkably. In fixed-wavelength method, it is difficult to measure temperature and H<sub>2</sub>O mole fraction, since the ratio of the peak values of absorbances is a function

of not only temperature but also mole fraction and wavelength as shown in Eq. (8). However, combustion oscillation can be detected by analysing frequency characteristics of transmitted signal. In addition, this fixed-wavelength method can be applied to high-pressure condition like gas turbine, where molecular absorption bands may be broad significantly. The advantage of the fixed-wavelength method is capability of detecting higher frequency oscillation more than 1 kHz.

## 6. Conclusions

Diode-laser absorption spectroscopy has been applied to the swirl-stabilized turbulent combustor to detect high frequency combustion oscillation and combustion state related to combustion noise.

Scanned-wavelength method has revealed that peak frequencies of temperature and H<sub>2</sub>O mole fraction correspond to those of the pressure fluctuation in the combustor, and that secondary fuel injections reduce the energies at peak frequencies and in high frequency region.

Intensity of fluctuation of the temperature shows minimal value when the secondary fuel is injected at appropriate frequency of 40 Hz.

In fixed-wavelength method, the power spectra of transmitted signals show the same tendency with those of temperature and H<sub>2</sub>O mole fraction obtained by the scanned-wavelength method.

Diode-laser absorption spectroscopy has high temporal resolution and high accuracy enough to detect turbulent combustion oscillation.

## Acknowledgement

This work was partially supported by Grant-in-Aid for Young Scientists (S) (no. 20676004) of Japan Society for the Promotion of

Science and by Grant-in-Aid for JSPS Fellows (no. 19-10540) of Japan Society for the Promotion of Science and research project [2007-CD12-P-01-3-010] of the Korea Energy Management Corporation.

## References

- [1] L. Rayleigh, *The Theory of Sound*, Dover, New York, 1945.
- [2] M.P. Arroyo, R.K. Hanson, *Appl. Opt.* 32 (1993) 6104–6116.
- [3] D.S. Baer, V. Nagali, E.R. Furlong, R.K. Hanson, M.E. Newfield, *AIAA Paper-95-0426* (1995).
- [4] J.H. Miller, S. Elreedy, B. Ahvazi, F. Woldu, P. Hassanzadeh, *Appl. Opt.* 32 (1993) 6082–6089.
- [5] R.R. Skaggs, J.H. Miller, *Proc. Combust. Inst.* 26 (1996) 1181–1188.
- [6] M.E. Webber, J. Wang, S.T. Sanders, D.S. Baer, R.K. Hanson, *Proc. Combust. Inst.* 28 (2000) 407–413.
- [7] J. Wang, M. Maiorov, J.B. Jeffries, D.Z. Garbuzov, J.C. Connolly, R.K. Hanson, *Meas. Sci. Technol.* 11 (11) (2000) 1576–1584.
- [8] D.M. Sonnenfroh, M.G. Allen, *Appl. Opt.* 36 (15) (1997) 3298–3300.
- [9] J.B. Jeffries, C. Schulz, D.W. Mattison, M.A. Oehlschlaeger, W.G. Bessler, T. Lee, D.F. Davidson, R.K. Hanson, *Proc. Combust. Inst.* 30 (2005) 1591–1599.
- [10] R.M. Mihalcea, D.S. Baer, R.K. Hanson, *AIAA Paper-96-0173* (1996).
- [11] J. Reid, D. Labrie, *Appl. Phys. B* 26 (1981) 203–210.
- [12] J.A. Silver, *Appl. Opt.* 31 (1992) 707–717.
- [13] D.M. Sonnenfroh, M.G. Allen, *Appl. Opt.* 36 (30) (1997) 7970–7977.
- [14] J.A. Silver, D.J. Kane, P.S. Greenberg, *Appl. Opt.* 34 (15) (1995) 2787–2801.
- [15] E.R. Furlong, D.S. Baer, R.K. Hanson, *Proc. Combust. Inst.* 26 (1996) 2851–2858.
- [16] E.R. Furlong, R.M. Mihalcea, M.E. Webber, D.S. Baer, R.K. Hanson, T.P. Parr, *AIAA Paper-97-2833* (1997).
- [17] E.R. Furlong, D.S. Baer, R.K. Hanson, *Proc. Combust. Inst.* 27 (1998) 103–111.
- [18] S.T. Sanders, T.P. Jenkins, J.A. Baldwin, D.S. Baer, R.K. Hanson, *AIAA Paper-2000-0358* (2000).
- [19] D.W. Mattison, C.M. Brophy, S.T. Sanders, L. Ma, K.M. Hinckley, J.B. Jeffries, R.K. Hanson, *J. Propul. Power* 19 (4) (2003) 568–572.
- [20] H.J. Li, X. Zhou, J.B. Jeffries, R.K. Hanson, *AIAA J.* 45 (2) (2007) 390–398.
- [21] L.S. Rothman, C.P. Rinsland, A. Goldman, S.T. Massie, D.P. Edwards, J.M. Flaud, A. Perrin, C. Camy-Peyret, V. Dana, J.Y. Mandin, J. Schroeder, A. Mccann, R.R. Gamache, R.B. Wattson, K. Yoshino, K.V. Chance, K.W. Jucks, L.R. Brown, V. Nemtchinov, P. Varanasi, J. Quant. Spectrosc. Radiat. Transfer 60 (1998) 665–710.
- [22] M. Tanahashi, S. Murakami, T. Miyauchi, G.-M. Choi, *Proceedings of the 5th Symposium on Smart Control of Turbulence Control of Oscillating Combustion and Measurements of Turbulent Flames*, Tokyo, 2004.
- [23] G.-M. Choi, M. Tanahashi, T. Miyauchi, *Proc. Combust. Inst.* 30 (2005) 1807–1814.